

Bluetooth sensors

Bluetooth environmental sensors for the Digiware system



gamme_869.psd

Function

B-TRH and **B-MAG** sensors communicate with DIRIS Digiware M gateways and DIRIS / ISOM Digiware D displays wirelessly via Bluetooth.

The B-TRH sensor allows you to integrate temperature and humidity data into your Digiware power monitoring system. This means that when it comes to improving your energy performance as per the ISO 50001 methodology, it is now possible to correlate energy consumption with the evolution of external factors. The sensor can also be used to anticipate maintenance work, by issuing an alert in the event of the electrical cabinet overheating or in the case of a leak, for example.

The B-MAG sensor is capable of detecting a loss of magnetic contact and will alert you upon the door opening of an electrical panel or restricted technical room.

Advantages

Effortless installation

- Integrated mounting accessory for easy installation.
- No additional wiring is required, the data is sent to the gateway or the display wirelessly via Bluetooth.
- Ultra-compact design that fits into the smallest of spaces.

Easy to configure

Automatic detection and pairing of sensors via the D-xx display or the M-xx gateway.

Maximum response

Sends real-time alerts when the measured temperature or humidity exceeds a predetermined threshold or when it detects a door opening.

General characteristics

Up to 16 sensors can be paired to the M-xx gateway or D-xx display to allow local and remote viewing on the WEBVIEW embedded web server.

The solution for

- > Data centre
- > Industry
- > Building



Strong points

- > Effortless installation
- > Easy to configure
- > Maximum response

Conformity to standards

- > EN 300 328 v2.2.0 (Radio)



- > ISO 14025

Create your own project

- > Find the best power monitoring system architecture:
www.meter-selector.com



Expert services



SERVICES
EXPERTS

Socomec offers a range of services to ensure a functional, accurate and reliable energy monitoring system as part of your

ISO 50001 strategy.

- Radio inspection.
- Start-up.

To find out more, ask your Socomec representative.

Communication architectures

The data measured by the B-TRH and B-MAG sensors can be viewed locally on the Digiware D display and on the embedded webserver WEBVIEW.

Digiware M/D gateways/displays provide this data on the Ethernet network via Modbus TCP/RTU, BACnet IP and SNMP protocols.

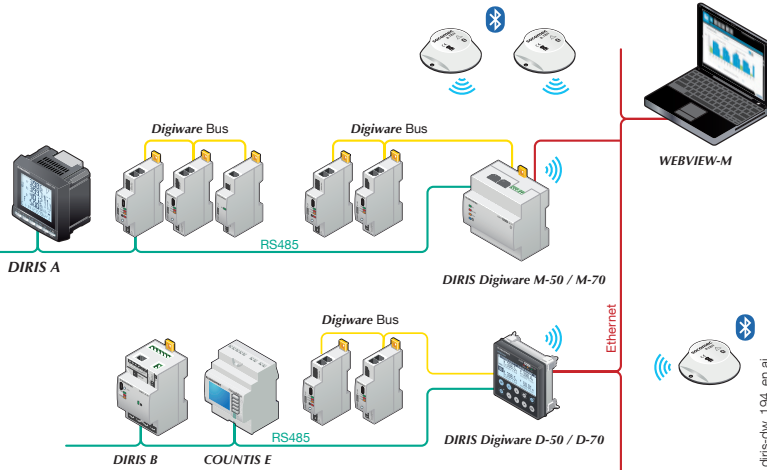

Dimensions

B-TRH and B-MAG

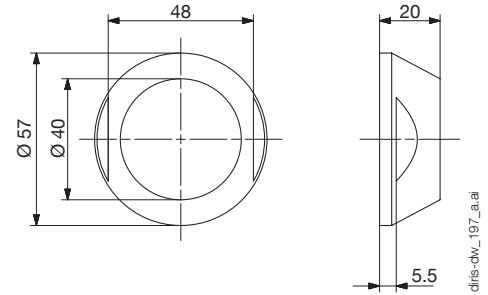

Mounting bracket

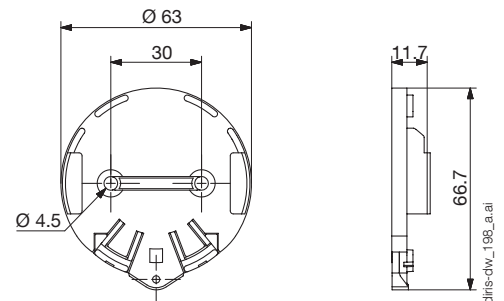

Technical characteristics

	B-TRH	B-MAG
Functional specifications		
Frequency	2.4 GHz – Bluetooth Low Energy 4.0/4.2	
Scope	Up to 500 metres free-field (+4 dBm)	
Transmission frequency	Adjustable from 0.1 to 10 seconds	Adjustable from 0.1 to 10 seconds
Battery properties		
Power supply	3 VDC – internal lithium battery	3 VDC – internal lithium battery
Service life	Up to 16 years	Up to 10 years
Measuring capacities		
Range	Temperature: -40 ... +85 °C Humidity: 0 ... 100%	-
Resolution	Temperature: 0.01 °C Humidity: 0.01%	-
Accuracy	Temperature: ± 0.4 °C Humidity: ±2.5% max (0 - 90%); ±3.5% max (90 - 100%)	-
Mechanical specifications		
Weight	41 g	41 g
Case materials	DELRIN (POM C)	DELRIN (POM C)
	Compatible with power supply units (90/128/EEC)	Compatible with power supply units (90/128/EEC)
Environmental specifications		
Protection degree	IP 65	IP 68
Temperature	-40 ... +85 °C	-40 ... +85 °C

References

Range of Bluetooth sensors		Reference
B-TRH	Temperature + humidity Bluetooth sensor	4829 0800
B-MAG	Magnetic contact Bluetooth sensor	4829 0801