

**Terminal shrouds mounting**  
**Montage des caches-bornes**  
**Montaje de cubrebornes**

38982040 2P  
 38983040 3P  
 38986040 4P

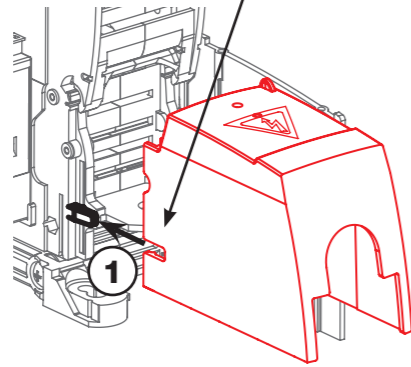

**Holding screw cover assembly**  
**Montage capot patte de fixation**  
**Montaje tapa para la pata de fijación**

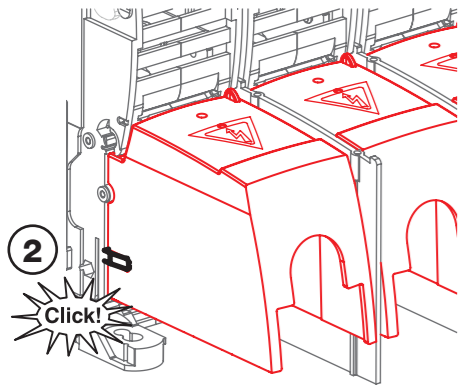
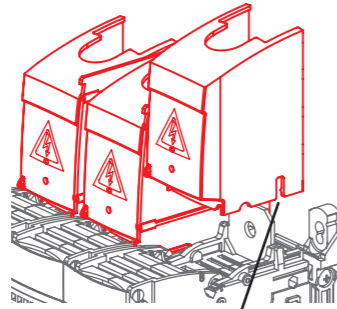
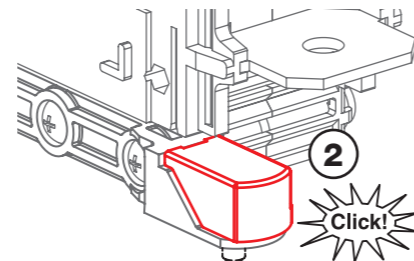
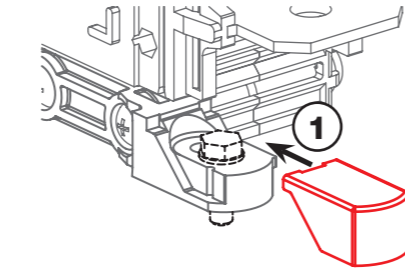

**Auxiliary contacts mounting**  
**Montage des contacts auxiliaires**  
**Montaje de los contactos auxiliares**

Maxi : 8 auxiliary contacts  
 Maxi : 8 contacts auxiliaires  
 Maxi : 8 contactos auxiliares

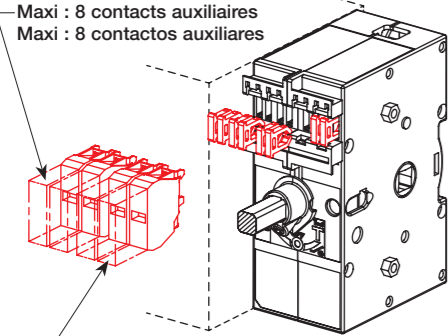

2 NO (F) : 39990701  
 2 NC (O) : 39990702

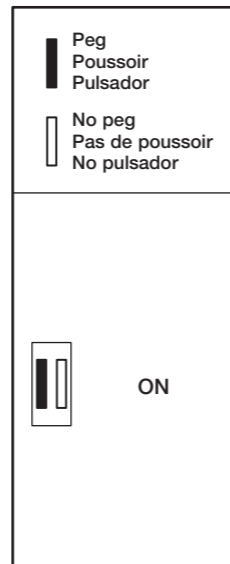

Click!

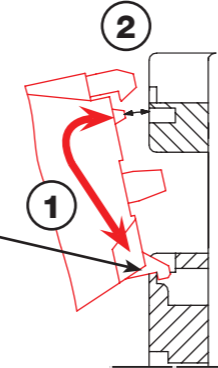
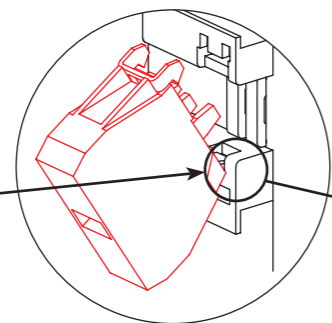
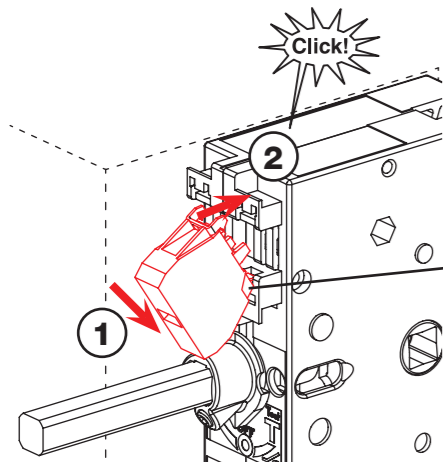

**⚠ DANGER / DANGER / PELIGRO**

**HAZARDOUS VOLTAGE**

- This equipment must be installed and serviced only by qualified electrical personnel.
- Turn off all power supplying this equipment before working on or inside equipment.
- Always use a properly rated voltage sensing device to confirm power is off.
- Replace all devices, doors, and covers before turning on power to this equipment.
- Maintain electrical clearances between cable and live parts.

**Failure to follow these instructions will result in death or serious injury.**

**TENSION DANGEREUSE**

- L'installation et l'entretien de cet appareil ne doivent être effectués que par du personnel qualifié.
- Coupez l'alimentation de cet appareil avant d'y travailler.
- Utilisez toujours un dispositif de détection de tension à valeur nominale approprié pour confirmer que toute alimentation est coupée.
- Remplacez tous les dispositifs, les portes et les couvercles avant de mettre cet appareil sous tension.
- Maintenez les distances d'isolement électrique entre le câble et les pièces sous tension.

**Si ces précautions ne sont pas respectées, cela entraînera la mort ou des blessures graves**

**TENSION PELIGROSA**

- Solamente el personal de mantenimiento eléctrico especializado deberá instalar y prestar servicios de mantenimiento a este equipo.
- Desenergice el equipo antes de realizar cualquier trabajo en él.
- Siempre utilice un dispositivo detector de tensión adecuado para confirmar la desenergización del equipo.
- Vuelva a colocar todos los dispositivos, las puertas y las cubiertas antes de energizar este equipo.
- Mantenga un espacio adecuado para la instalación eléctrica entre el cable y las piezas energizadas.

**El incumplimiento de estas precauciones podrá causar la muerte o lesiones serias.**

- 1 38512038
- 2 38513038
- 3 38516038

Dual dimensions in/mm  
 Double dimensions in/mm  
 Doble dimensiones in/mm

RECTO-VERSO / S blanc offset 100g/m² / I Noire pantone black C -Rouge pantone 485U / F 297x420

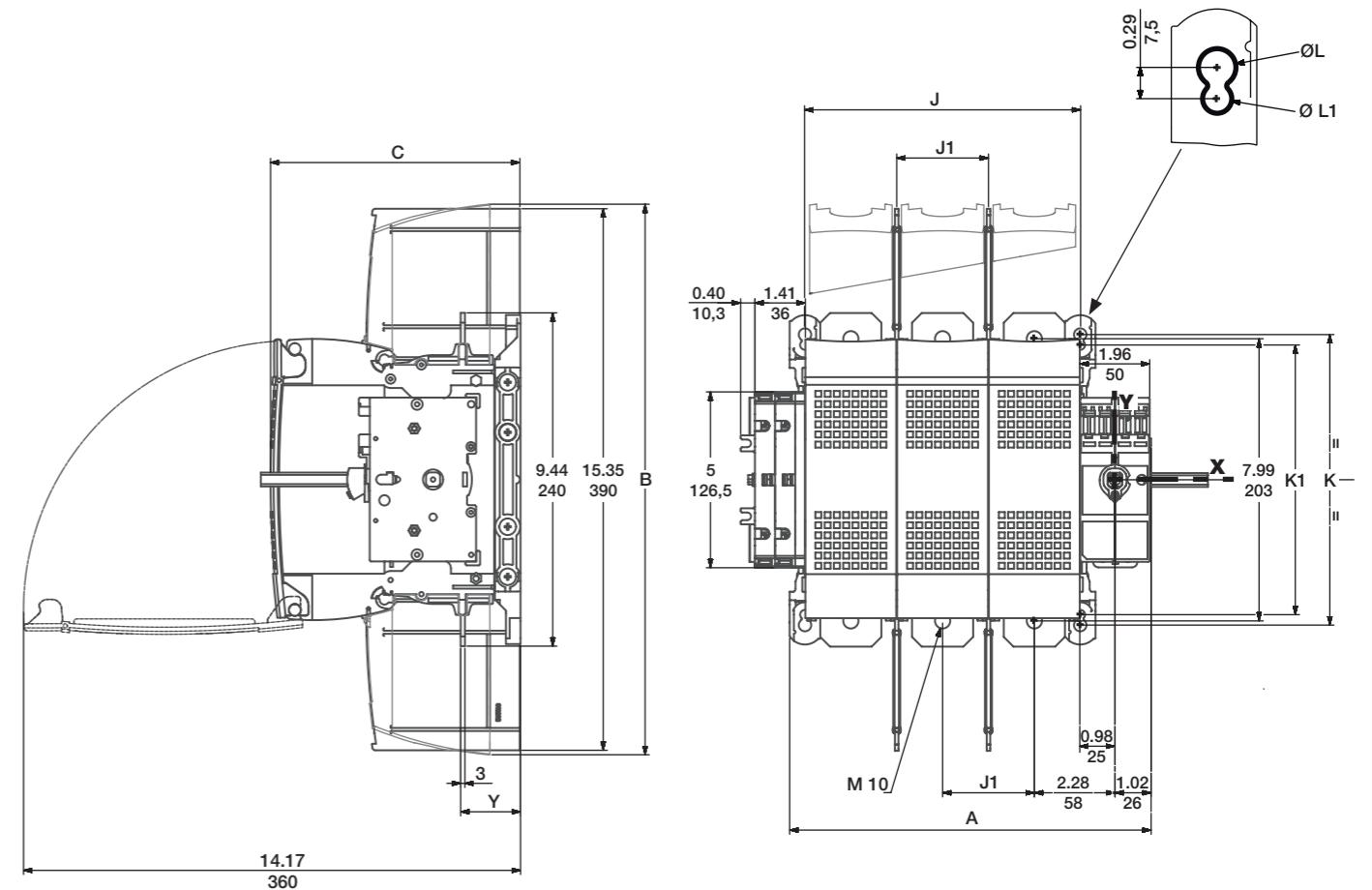

	A		B		C		J		J1		K		K1		ØL		ØL1		Y		
	in	mm	in	mm	in	mm	in	mm	in	mm	in	mm	in	mm	in	mm	in	mm	in	mm	
400A	1	7.64	194	15.61	396.5	7.09	180	5.20	132	2.60	66	8.23	209	7.64	194	0.35	9	0.27	7	1.69	43
	2	10.24	260					7.80	198												
	3	12.83	326					10.39	264												

- 1 38512038
- 2 38513038
- 3 38516038

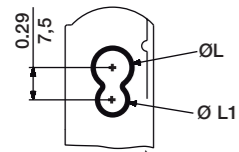

**Front operation**  
**Commande frontale**  
**Mando frontal**

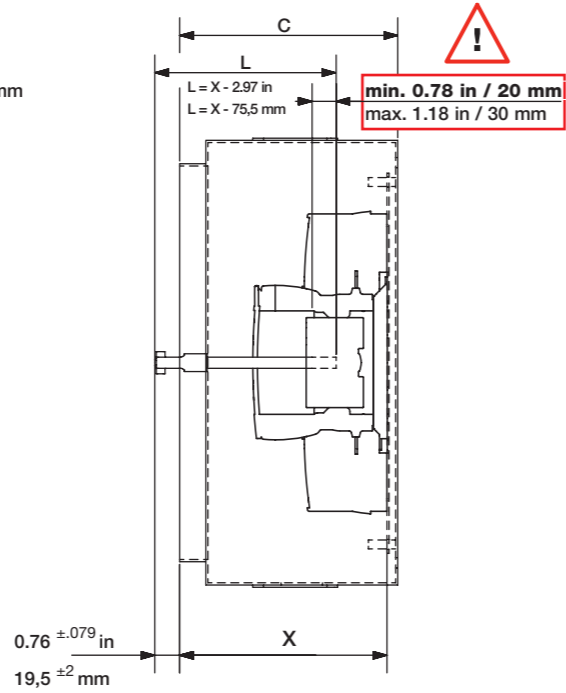
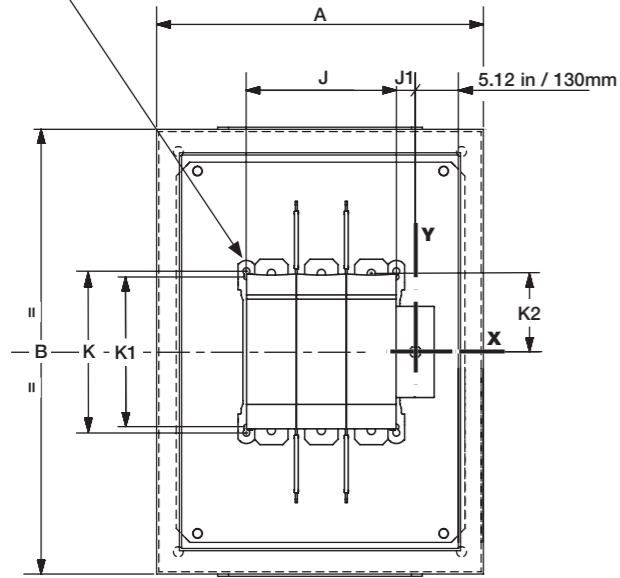

**Side operation**  
**Commande latérale**  
**Mando lateral**

- 1 Insert the shaft until the end stopper.  
Engager axe à fond dans la mécanique.  
Insertar hasta el fondo.
- 2 Set up the length (L). Cut.  
Définir longueur (L). Couper.  
Calcular la medida (L). Cortar.
- 3 Check the 0.76 ±0.079 in / 19,5 ±2 mm dimension.  
Vérifier cote 0.76 ±0.079 in / 19,5 ±2 mm  
Verificar la medida 0.76 ±0.079 in / 19,5 ±2 mm

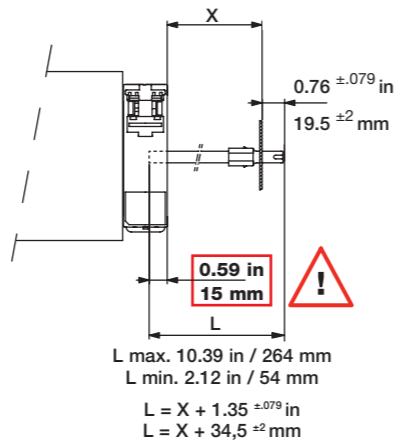

Minimum enclosure dimensions  
 Dimensions minimum des coffrets  
 Dimensiones mínimas de las cajas

	A		B		C		J		J1		K		K1		K2		Ø L		Ø L1			
	in	mm	in	mm	in	mm	in	mm	in	mm	in	mm	in	mm	in	mm	in	mm	in	mm		
400A	1	2 P	31.49	800	39.37	1000	11.81	300	5.20	132	0.98	25	8.23	209	7.64	194	3.99	101,5	0.36	9	0.27	7
	2	3 P							7.80	198												
	3	4 P							10.39	264												

**Terminal lugs mounting**  
**Montage des bornes à cages**  
**Montaje de bornes de conexión**

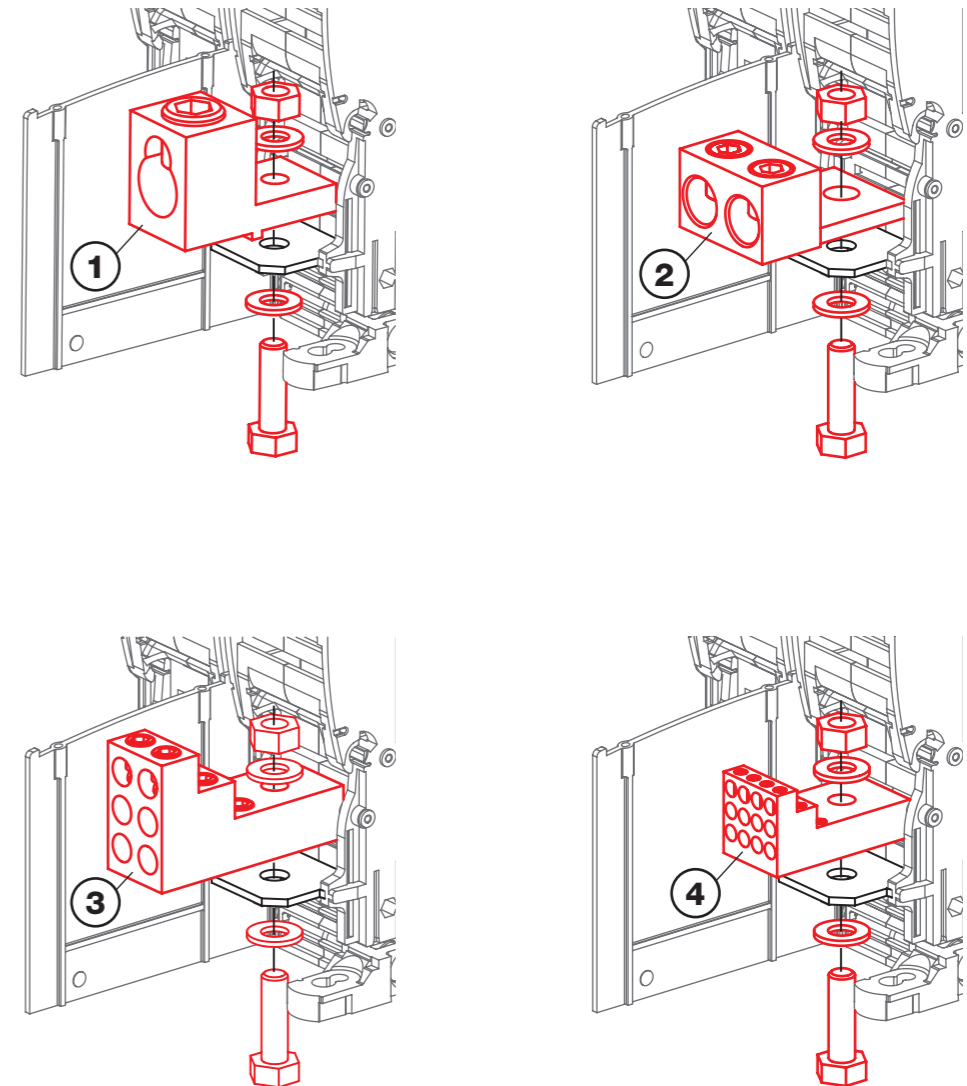

Ref. lugs Ref. bornes à cage Ref. bornes	Designation Désignation Designación	Quantity per reference. Quantité par ref. Cantidad por referencia	Size / Section Sección ( AWG )		Openings per lug. Nombre de points de connexion. Numero de puntos de conexión.	Torque Couple Par de apriete		Size
			min.	max.		lb-in	Nm	
39542040 39543040 39544040	CMC LA-630R 1	2 3 4	# 4 1/0	600 Kcmil 250 Kcmil	1 2	310 35	17	
39542041 39543041 39544041	PANDUIT LAM2A 350-12-6Y 2	2 3 4	# 6	350 Kcmil	2	398 45	17	
39542640 39543640 39544640	3	2 3 4	# 2 # 6 # 8 # 12	# 2/0 # 4 # 8 # 10	6	310 35	17	
39542124 39543124 39544124	4	2 3 4	# 6 # 8 # 12	# 4 # 8 # 10	12	310 35	17	