



ATyS A - ATyS C

Automatic Transfer Switching Equipment
from 125 to 3200 A with split ATS controller

Transfer switches



Function

ATyS A and **ATyS C** are 4 pole automatic transfer switches, with positive break indication. They incorporate the functions intended for mains/mains applications and mains/genset applications.

In automatic mode they enable the monitoring of, and the on-load changeover between, two power supply sources, in accordance with the parameters configured via DIP switches. They are intended for use in low voltage power supply systems where a brief interruption of the load supply is acceptable during transfer.

Remote monitoring of the ATyS C is possible through RS485 communication.

Advantages

Rapid commissioning

Voltage tapping and cable harness are supplied in a single package with motorised transfer switch and ATS controller. ATyS A and C switches offer significant time saving during commissioning (process takes 2 to 3 minutes). Owing to the design that allows commissioning through eight DIP switches, a screwdriver is all that is required to configure even non-powered the controller.

ATyS C with RS485 communication

An RS485 communication offers the remote monitoring possibilities of available power sources and their parameters, timers. Communication speed is up to 38400 bauds.

Split design

The split design of the transfer switch offers an easy door mounting possibility of the ATS controller. Whilst providing an IP4x protection degree it enables an access to source availability and switch position visual information, as well as to the manual remote controls option.

General characteristics

- Main/Main or Main/Genset networks.
- ATS with 3 stable positions : I - 0 - II.
- Built-in mechanical interlock.
- Emergency manual operation handle.
- Top or bottom incoming sources.
- ATS controller self-powered from sensing : 184 - 300 VAC.
- ATS controller optional 24 VDC aux power supply.
- Three-phase + Neutral or Single-phase + Neutral networks.
- Voltage sensing on all phases.
- Phase rotation checking.
- RS485 Modbus communication with ATyS C
- Door or DIN rail mounted controller.

Watchdog relay to check product availability

ATyS A and ATyS C products are equipped with a Watchdog relay which constantly monitors your product, thereby securing the installation. This relay informs in real time the user of the product's availability, i.e. whether it is operational and ready for source switching.

Cable harness

The cable harness is an easy way of powering ATyS A or ATyS C transfer switch systems. It's equipped with voltage tap offs and provides a reliable link between controller and changeover switch for:

- tracking power sources availability,
- monitoring changeover switch availability,
- an electrical interlock function,
- control and transfer between power sources.

Cable harness length is approximately 2 meters.

The solution for

- > Mains/mains and Mains/Genset applications
- > With RS485 communication (ATyS C) or basic ATS controller (ATyS A)



Strong points

- > Fully certified ATSE with door mounted controller
- > ATS controller with integrated AC Double Power Supply and functions dedicated to mains/mains or mains/genset applications
- > RS485 Communication with ATyS C

Conformity to standards

- > IEC 60947-6-1
- > GB/T 14048.11
- > IEC 60947-3
- > IEC 61010-2-201 (ATS controller)



Front panel of the controller



1. Controller status indication.
2. Configuration dip-switches.
3. Lamp test / Test on Load (3s).
4. Position orders (in Manual).
5. Auto/Manu mode selector.
6. Mimic panel.

1 2 3 4 5 6 7 8									
A		Res						B	
1	2	3	4	5	6	7	8		
Network	Prio set	Order Mod	ΔU ΔF	ODT	FT	RT			
3P+N A	S1 A	Pulse A	10% 5% A	2s A	3s A	0 min A	A		
1P+N B	no prio B	Maint. B	20% 10% B	0s B	10s B	10 min B	A		
						30min B	B		

ODT: Dead band timer RT: Return timer
FT: Failure timer Res: Set/Reset button

DIP switches allow quick and easy configuration. It's not required to power the controller during configuration. After powering on it will read the latest DIP switches values.

References

ATyS A - ATyS C

Rating (A) / Frame size	No. of poles	ATyS A	ATyS C with RS485 communication	Bridging bars	Terminal shrouds	Terminal screens	Auxiliary contact
125 A / B3	4 P	9515 4012	9525 4012				
160 A / B3	4 P	9515 4016	9525 4016	4109 4019	2694 4014 ⁽²⁾	1509 4012	
200 A / B3	4 P	9515 4020	9525 4020				
250 A / B4	4 P	9515 4025	9525 4025	4109 3025			
315 A / B4	4 P	9515 4031	9525 4031	4109 4039	2694 4021 ⁽²⁾	1509 4025	1599 0502
400 A / B4	4 P	9515 4040	9525 4040				
500 A / B5	4 P	9515 4050	9525 4050	4109 3050			
630 A / B5	4 P	9515 4063	9525 4063	4109 3063	2694 4051 ⁽²⁾	1509 4063	
800 A / B6	4 P	9515 4080	9525 4080	4109 4080			
1000 A / B6	4 P	9515 4100	9525 4100			1509 4080	
1250 A / B6	4 P	9515 4120	9525 4120	4109 3120			1599 0532
1600 A / B7	4 P	9515 4160	9525 4160	4109 3160		1509 3160	
2000 A / B8	4 P	9515 4200	9525 4200				
2500 A / B8	4 P	9515 4250	9525 4250	(1)		1509 4200	included
3200 A / B8	4P	9515 4320	9525 4320				

(1) See "Copper bar connection pieces".

(2) To fully shroud front, rear, top and bottom 4 references required.
To shroud front switch top and bottom 2 references required.

ATyS A - ATyS C

Automatic Transfer Switching Equipment
from 125 to 3200 A with split ATS controller

Accessories

Terminal shrouds

Use

IP2X protection against direct contact with terminals or connecting parts.

Advantages

Perforations allow remote thermographic inspection without the need to remove the shrouds.

Rating (A)	Frame size	No. of poles	Position	Reference
125 ... 200	B3	4 P	top / bottom / front (I) / rear (II)	2694 4014 ⁽¹⁾⁽²⁾
250 ... 400	B4	4 P	top / bottom / front (I) / rear (II)	2694 4021 ⁽¹⁾⁽²⁾
500 ... 630	B5	4 P	top / bottom / front (I) / rear (II)	2694 4051 ⁽¹⁾⁽²⁾

(1) For complete shrouding at front, rear, top and bottom, order quantity 4; if equipped with bridging bars order quantity 3.
(2) For top and bottom shrouding for the front only, order quantity 2.



access_206_a_2_cat

Terminal screens

Use

Upstream and downstream protection against direct contact with terminals or connection parts.
For upstream and downstream protection, order quantity 1.

Rating (A)	Frame size	No. of poles	Position	Reference
125 ... 200	B3	4 P	top / bottom	1509 4012
250 ... 400	B4	4 P	top / bottom	1509 4025
500 ... 630	B5	4 P	top / bottom	1509 4063
800 ... 1250	B6	4 P	top / bottom	1509 4080
1600	B7	4 P	top / bottom	1509 4160
2000 ... 3200	B8	4 P	top / bottom	1509 4200



access_207_a_2_cat

Inter-phase barrier

Use

Safe isolation between the terminals, essential for use at 690 VAC or in a polluted or dusty atmosphere.

Rating (A)	Frame size	No. of poles	Reference
125 ... 200	B3	4 P	2998 0034
250 ... 400	B4	4 P	2998 0024
500 ... 630	B5	4 P	2998 0014
800 ... 3200	B6 ... B8	4 P	included

Bridging bars

Use

For bridging power terminals on the upstream or downstream side of the switch.
One reference required per ATyS.

Rating (A)	Frame size	No. of poles	Section (mm)	Reference
125 ... 200	B3	4 P	20 x 2.5	4109 4019
250	B4	4 P	25 x 2.5	4109 4025
315 ... 400	B4	4 P	32 x 5	4109 4039
500	B5	4 P	32 x 5	4109 4050
630	B5	4 P	50 x 5	4109 4063
800 ... 1000	B6	4 P	50 x 6	4109 4080
1250	B6	4 P	60 x 8	4109 4120
1600	B7	4 P	90 x 10	4109 4160

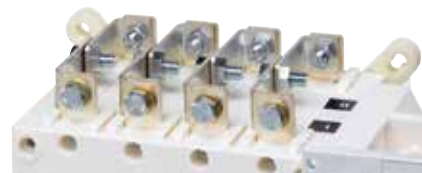

access_205_a_2_cat

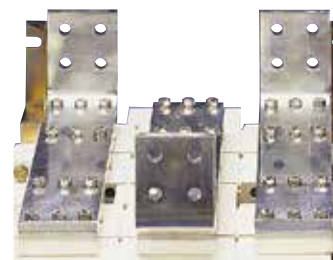

access_041_La_1_cat

Copper bar connection pieces

Use

For ratings 2000 to 3200 A.

Enables:

- Flat connection: the connection pieces provide a link between the two power terminals of the same pole (Fig. 1).
- Edgewise connection: the connection pieces provide a link between the two power terminals of the same pole and an edgewise bar connection terminal.
- Top or bottom bridging between two poles (Fig. 3).

Once installed, the power terminal is connection ready.

For 3200 A rating, connection pieces (part A) are supplied as standard. Bolt sets must be ordered separately.

Connection: the quantities given in the below table refer to the number of pieces required per pole, top or bottom.

Bridging connection: the quantities given refer to the number of pieces required to complete a single bridging connection between two poles.

	Reference	2000 – 2500 A			3200 A		
		Fig. 1	Fig. 2	Fig. 3	Fig. 1	Fig. 2	Fig. 3
		Connection		Bridging connection I - II	Connection		Bridging connection I - II
Connection - part A	2619 1200	1	1		2 ⁽²⁾	included	
Bolt kit 35 mm - part B	2699 1201	1 ⁽¹⁾		2 ⁽²⁾	1 ⁽¹⁾		2 ⁽²⁾
Bolt kit 45 mm - part B	2699 1200	1 ⁽¹⁾			1 ⁽¹⁾		
T + Bolt kit - part C	2629 1200		1	1		1	1
Bracket + bolt kit - part D	2639 1200		1			1	
Bar + bolt kit - part E	4109 0320			1			1

(1) Choose the bolt length according to the thickness of the bars being connected; if bar thickness is greater than 20 mm, 45 mm bolts are required.

(2) For bridging connections, quantity 2 pieces are required for creating the link between the two power terminals of the same pole for switch bodies I and II.

The quantities of the applicable pieces then need to be multiplied by the number of connection points (power terminals) in order to determine the total quantity required of each part.

Example: For a 4 pole 2500 A SIRCOVER with upstream edgewise connection (Fig. 2) and downstream bridging (Fig. 3), the following quantities will be required:

Part	Upstream edgewise quantity	Downstream bridging quantity	Total quantity
A	8	8	16
B	0	8	8
C	8	4	12
D	8	0	8
E	0	4	4

Fig. 1

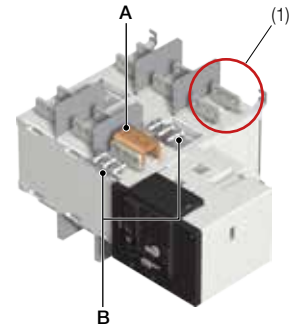

access_459_a_1_x_cat

(1) Single pole connection: 1 pole (top or bottom) comprises two power terminals which are to be linked with the copper connection kit.

Fig. 2

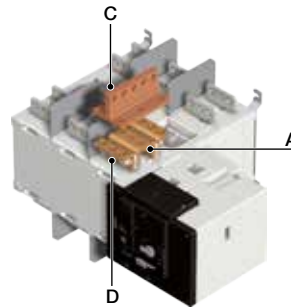

access_460_a_1_x_cat

Fig. 3

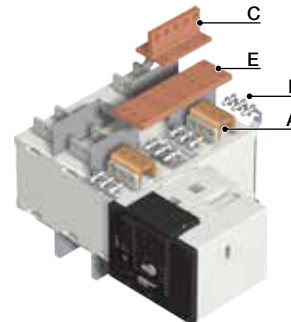

access_461_a_1_x_cat

Solid neutral

Use

The solid neutral kit provides connection between the incoming and outgoing neutrals with no disconnection during transfer.

Rating (A)	Frame size	Reference
125 ... 200	B3	9509 0012
200 ... 315	B4	9509 0025
400	B4	9509 0040
500 ... 630	B5	9509 0063
800 ... 1000	B6	9509 0080
1250	B6	9509 0120
1600	B7	9509 0160

ATyS A - ATyS C

Automatic Transfer Switching Equipment
from 125 to 3200 A with split ATS controller

Accessories (continued)

Autotransformer

Use

For applications without neutral, this autotransformer provides the 230 VAC required to power these ATyS products.

Rating (A)	Frame size	Reference
125 ... 3200	B3 ... B8	1599 4064

DC power supply

Use

Allows an ATyS to be supplied from a 12 or 24 VDC source. To be positioned as close as possible to the DC power supply source.

Rating (A)	Frame size	Operating voltage	Reference
125 ... 1600	B3 ... B7	12 VDC / 230 VAC	1599 5012
125 ... 1600	B3 ... B7	24 VDC / 230 VAC	1599 5112
125 ... 1600	B3 ... B7	48 VDC / 230 VAC	1599 5212

Auxiliary contact

Use

Pre-break and signalling of positions I and II: each reference provides 1 NO/NC auxiliary contact for positions I and II. Possibility to install up to 2 auxiliary contacts for each position.

Low level AC: contact us. ATyS are supplied with 1 NO aux contact for all three positions as standard.



800 to 1600 A

If additional auxiliary contacts are required please consult us.

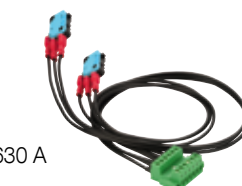

125 to 630 A

Rating (A)	Frame size	Nominal current (A)	Operating current I _o (A)			
			250 VAC AC-13	400 VAC AC-13	24 VDC DC-13	48 VDC DC-13
125 ... 3200	B3 ... B8	16	12	8	14	6

Rating (A)	Frame size	Type of mounting	Reference
125 ... 630	B3 ... B5	Customer fit	1599 0502
800 ... 1600	B6 ... B7	Customer fit	1599 0532
2000 ... 3200	B8	-	2 AC per position fitted as standard

Auto/Manual key selector

Use

Replaces the standard Auto/Manual selector knob with a key selector.

Rating (A)	Frame size	Reference
125 ... 3200	B3 ... B8	9599 1007

Motorisation module

The motor units of the ATyS are easy to replace in case there is a problem, even when on-load.

Rating (A)	Reference
125 ... 200	9509 5020
250 ... 400	9509 5040
500 ... 630	9509 5063
800 ... 1250	9509 5120
1600	9509 5160
2000 ... 3200	9509 5320



atys_571_a

Switching module

If you need to replace just the switching part on an ATyS order SIRCOVER items. Please refer to "SIRCOVER" pages.



sv_151_a

Characteristics of ATS controllers

Characteristics

Electrical characteristics	
AC operating limits	184 ⁽¹⁾ - 300 VAC
Optional DC supply	24 VDC
Frequency limits	45 - 65 Hz
Power consumption	< 10 W
Inputs	5 - fixed (auto inhibit & 24 VDC fire input, position indication I-0-II)
Outputs	4 - fixed (position control I-0-II & genset start)
Impulse withstand	6/4 kV ⁽²⁾
Overvoltage category	CAT 3

Mechanical characteristics	
Weight	845 gr
Door cutout	138 x 93 mm
Operating temperature	-25 ... +60°C
Communications ATyS C	
Interface type	RS485. 2 to 3 half duplex wires
Protocol	MODBUS RTU
Baudrate	38400

(1) 190 VAC in contactor mode.

(2) 6 kV tested between phases of a different source and 4 kV tested between phases of a the same source.

Dimensions of ATS controllers

Dimensions (mm)

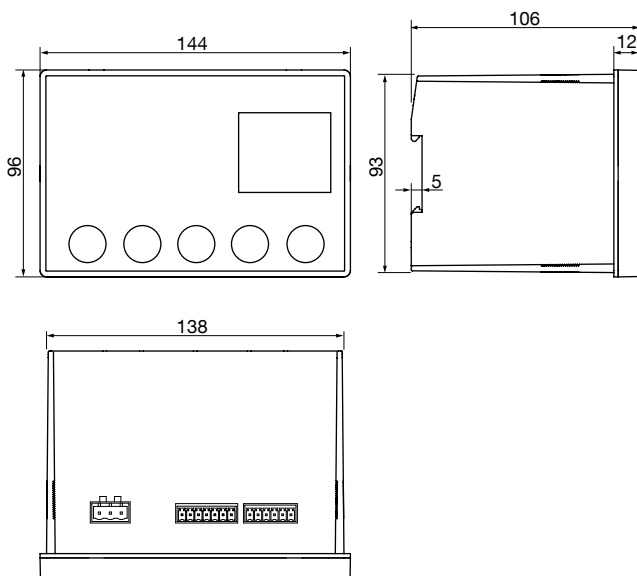

atysc_001_b_1_x_cat.ai

ATyS A - ATyS C

Automatic Transfer Switching Equipment

from 125 to 3200 A with split ATS controller

Characteristics according to IEC 60947-3 and IEC 60947-6-1

125 to 630 A

Thermal current I_{th} to 40°C	125 A	160 A	200 A	250 A	315 A	400 A	500 A	630 A	
Frame size	B3	B3	B3	B4	B4	B4	B5	B5	
Rated insulation voltage U_i (V) (power circuit)	800	800	800	1000	1000	1000	1000	1000	
Rated impulse withstand voltage U_{imp} (kV) (power circuit)	8	8	8	12	12	12	12	12	
Rated insulation voltage U_i (V) (control circuit)	300	300	300	300	300	300	300	300	
Rated impulse withstand voltage U_{imp} (kV) (control circuit)	4	4	4	4	4	4	4	4	
Rated operational currents I_e (A) according to IEC 60947-3									
Rated voltage	Utilisation category	A/B⁽¹⁾	A/B⁽¹⁾	A/B⁽¹⁾	A/B⁽¹⁾	A/B⁽¹⁾	A/B⁽¹⁾	A/B⁽¹⁾	A/B⁽¹⁾
415 VAC	AC-21 A / AC-21 B	125/125	160/160	200/200	250/250	315/315	400/400	500/500	630/630
415 VAC	AC-22 A / AC-22 B	125/125	160/160	200/200	250/250	315/315	400/400	500/500	630/630
415 VAC	AC-23 A / AC-23 B	125/125	160/160	200/200	200/200	315/315	400/400	500/500	500/630
500 VAC	AC-21 A / AC-21 B	125/125	160/160	200/200	250/250	315/315	400/400	500/500	630/630
500 VAC	AC-22 A / AC-22 B	125/125	160/160	200/200	200/250	200/315	200/400	500/500	500/500
500 VAC	AC-23 A / AC-23 B	80/80	80/80	80/80	200/200	200/200	200/200	400/400	400/400
690 VAC ⁽³⁾	AC-21 A / AC-21 B	125/125	160/160	200/200	200/200	200/200	200/200	500/500	500/500
690 VAC ⁽³⁾	AC-22 A / AC-22 B	125/125	125/125	125/125	160/160	160/160	160/160	400/400	400/400
690 VAC ⁽³⁾	AC-23 A / AC-23 B	63/80	63/80	63/80	125/125	125/125	125/125	400/400	400/400
220 VDC	DC-21 A / DC-21 B	125/125	160/160	200/200	250/250	250/250	250/250	500/500	630/630
220 VDC	DC-22 A / DC-22 B	125/125	160/160	200/200	250/250	250/250	250/250	500/500	630/630
220 VDC	DC-23 A / DC-23 B	125/125	125/125	125/125	200/200	200/200	200/200	500/500	630/630
440 VDC ⁽²⁾	DC-21 A / DC-21 B	125/125	125/125	125/125	200/200	200/200	200/200	500/500	630/630
440 VDC ⁽²⁾	DC-22 A / DC-22 B	125/125	125/125	125/125	200/200	200/200	200/200	500/500	630/630
440 VDC ⁽²⁾	DC-23 A / DC-23 B	125/125	125/125	125/125	200/200	200/200	200/200	500/500	630/630
Rated operational currents I_e (A) according to IEC 60947-6-1									
Rated voltage	Utilisation category								
415 VAC	AC-31 B	125	160	200	250	315	400	500	630
415 VAC	AC-32 B				200	315	400	500	500
415 VAC	AC-33 B				200	200	200	400	400
Current rated as conditional short-circuit with fuse gG DIN, according to IEC 60947-3									
Prospective fuse protected short-circuit withstand at 415 VAC ⁽⁶⁾		100	100	50	50	50	50	50	50
Prospective fuse protected short-circuit withstand at 690 VAC(kA rms)					50	50	50	50	50
Associated fuse rating (A)		125	160	200	250	315	400	500	630
Short-circuit withstand without protection as per IEC 60947-3									
Rated short-time withstand current 0.3s I_{cw} at 415 VAC (kA rms)		12	12	12	15 ⁽⁴⁾	15 ⁽⁴⁾	15 ⁽⁴⁾	17 ⁽⁴⁾	17 ⁽⁴⁾
Rated short-time withstand current 1s I_{cw} at 415 VAC (kA rms)		7	7	7	8 ⁽⁴⁾	8 ⁽⁴⁾	8 ⁽⁴⁾	11 ⁽⁴⁾	10 ⁽⁴⁾
Rated peak withstand current at 415 VAC (kA peak)		20	20	20	30	30	30	45	45
Short-circuit withstand without protection as per IEC 60947-6-1									
Rated short-time withstand current 30 ms I_{cw} at 415 VAC (kA rms)		10	10	10	10	10	10		
Rated short-time withstand current 60 ms I_{cw} at 415 VAC (kA rms)								10	12.6
Connection									
Minimum Cu cable cross-section (mm ²)		35	35	50	95	120	185	2 x 95	2 x 120
Recommended Cu busbar cross-section (mm ²)								2 x 32 x 5	2 x 40 x 5
Maximum Cu cable cross-section (mm ²)		50	95	120	150	240	240	2 x 185	2 x 300
Maximum Cu busbar width (mm)		25	25	25	32	32	32	50	50
Min./max. tightening torque (Nm)		9/13	9/13	9/13	20/26	20/26	20/26	40/45	40/45
Switching time (rated voltage, after receiving command)									
Transfer time I-II or II-I (s)		0.85	0.85	0.85	0.9	0.9	0.9	0.95	0.95
I-0 or II-0 (s)		0.55	0.55	0.55	0.5	0.5	0.5	0.55	0.55
Contact transfer time ("black-out" I-II) minimum (s)		0.3	0.3	0.3	0.4	0.4	0.4	0.4	0.4
Power supply									
Min./max. power (VAC)		166/332	166/332	166/332	166/332	166/332	166/332	166/332	166/332
Control supply power demand									
Demand/rated power (VA) - ATyS		184/92	184/92	184/92	276/115	276/115	276/115	276/150	276/150
Mechanical specifications									
Durability (number of operating cycles)		10,000	10,000	10,000	8,000	8,000	8,000	5,000	5,000
Weight ATyS 4 P (kg)		6.9	6.9	6.9	7.4	7.8	7.8	13.3	14.0

(1) Category with index A = frequent operation - Category with index B = infrequent operation.

(2) 4-pole device with 2 poles in series by polarity.

(3) Interphase barriers must be installed on the products.

(4) Values given at 690 VAC.

800 to 3200 A

Thermal current I_{th} at 40°C	800 A	1000 A	1250 A	1600 A	2000 A	2500 A	3200 A
Frame size	B6	B6	B6	B7	B8	B8	B8
Rated insulation voltage U_i (V) (power circuit)	1000	1000	1000	1000	1000	1000	1000
Rated impulse withstand voltage U_{imp} (kV) (power circuit)	12	12	12	12	12	12	12
Rated insulation voltage U_i (V) (control circuit)	300	300	300	300	300	300	300
Rated impulse withstand voltage U_{imp} (kV) (control circuit)	4	4	4	4	4	4	4
Rated operational currents I_e (A) according to IEC 60947-3							
Rated voltage	Utilisation category	A/B⁽¹⁾	A/B⁽¹⁾	A/B⁽¹⁾	A/B⁽¹⁾	A/B⁽¹⁾	A/B⁽¹⁾
415 VAC	AC-21 A / AC-21 B	800/800	1000/1000	1250/1250	1600/1600	-/2000	-/2500
415 VAC	AC-22 A / AC-22 B	800/800	1000/1000	1250/1250	1600/1600	-/2000	-/2500
415 VAC	AC-23 A / AC-23 B	800/800	1000/1000	1250/1250	1250/1250	-/1600	-/1600
500 VAC	AC-21 A / AC-21 B	800/800	1000/1000	1250/1250	1600/1600	-/2000	-/2000
500 VAC	AC-22 A / AC-22 B	630/630	800/800	1000/1000	1600/1600		
500 VAC	AC-23 A / AC-23 B	630/630	630/630	800/800	1000/1000		
690 VAC ⁽³⁾	AC-21 A / AC-21 B	800/800	1000/1000	1250/1250	1600/1600	-/2000	-/2000
690 VAC ⁽³⁾	AC-22 A / AC-22 B	630/630	800/800	1000/1000	1000/1000		
690 VAC ⁽³⁾	AC-23 A / AC-23 B	630/630	630/630	800/800	800/800		
220 VDC	DC-21 A / DC-21 B	800/800	1000/1000	1250/1250	1250/1250		
220 VDC	DC-22 A / DC-22 B	800/800	1000/1000	1250/1250	1250/1250		
220 VDC	DC-23 A / DC-23 B	800/800	1000/1000	1250/1250	1250/1250		
440 VDC ⁽²⁾	DC-21 A / DC-21 B	800/800	1000/1000	1250/1250	1250/1250		
440 VDC ⁽²⁾	DC-22 A / DC-22 B	800/800	1000/1000	1250/1250	1250/1250		
440 VDC ⁽²⁾	DC-23 A / DC-23 B	800/800	1000/1000	1250/1250	1250/1250		
Rated operational currents I_e (A) according to IEC 60947-6-1							
Rated voltage	Utilisation category						
415 VAC	AC-31 B	800	1000	1250	1600	2000	2500
415 VAC	AC-32 B	800	1000	1250	1250	2000	2000
415 VAC	AC-33 B	800	1000	1000	1000	1250	1250
Current rated as conditional short-circuit with fuse gG DIN, according to IEC 60947-3							
Prospective fuse protected short-circuit withstand at 415 VAC(kA rms)	50	50	100	100			
Prospective fuse protected short-circuit withstand at 690 VAC(kA rms)	50	50	50				
Associated fuse rating (A)	800	1000	1250	2x800			
Short-circuit withstand without protection as per IEC 60947-3							
Rated short-time withstand current 0.3s I_{ow} at 415 VAC (kA rms)	64	64	64	78	78	78	78
Rated short-time withstand current 1s I_{ow} at 415 VAC (kA rms)	35	35	35	50	50	50	50
Rated peak withstand current at 415 VAC (kA peak)	55	55	80	110	120	120	120
Short-circuit withstand without protection as per IEC 60947-6-1							
Rated short-time withstand current 30 ms I_{ow} at 415 VAC (kA rms)							
Rated short-time withstand current 60 ms I_{ow} at 415 VAC (kA rms)	20	20	25	32	50	50	50
Connection							
Minimum Cu cable cross-section (mm ²)	2 x 185						
Recommended Cu busbar cross-section (mm ²)	2 x 50 x 5	2 x 63 x 5	2 x 60 x 7	2 x 100 x 5	3 x 100 x 5	2 x 100 x 10	3 x 100 x 10
Maximum Cu cable cross-section (mm ²)	4 x 185	4 x 185	4 x 185	6 x 185			
Maximum Cu busbar width (mm)	63	63	63	100	100	100	100
Min./max. tightening torque (Nm)	9/13	9/13	20/26	40/45	40/45	40/45	40/45
Switching time (rated voltage, after receiving command)							
Transfer time I-II or II-I (s)	2.8	2.8	2.8	2.9	2.8	2.8	2.8
I-0 or II-0 (s)	1.4	1.4	1.4	1.4	1.8	1.8	1.8
Contact transfer time ("black-out" I-II) minimum (s)	1.4	1.4	1.4	1.5	1	1	1
Power supply							
Min./max. power (VA)	166/332	166/332	166/332	166/332	166/332	166/332	166/332
Control supply power demand							
Demand/rated power (VA) - ATyS	460/184	460/184	460/184	460/230	812/322	812/322	812/322
Mechanical specifications							
Durability (number of operating cycles)	4,000	4,000	4,000	3,000	3,000	3,000	3,000
Weight ATyS 4 P (kg)	32.2	32.9	33.6	39.4	61.6	61.6	75.3

(1) Category with index A = frequent operation - Category with index B = infrequent operation.
(2) 4-pole device with 2 poles in series by polarity.
(3) Interphase barriers must be installed on the products.
(4) Values given at 690 VAC.

ATyS A - ATyS C

Automatic Transfer Switching Equipment
from 125 to 3200 A with split ATS controller

Connections and terminals

ATS controller connection with ATyS transfer switch

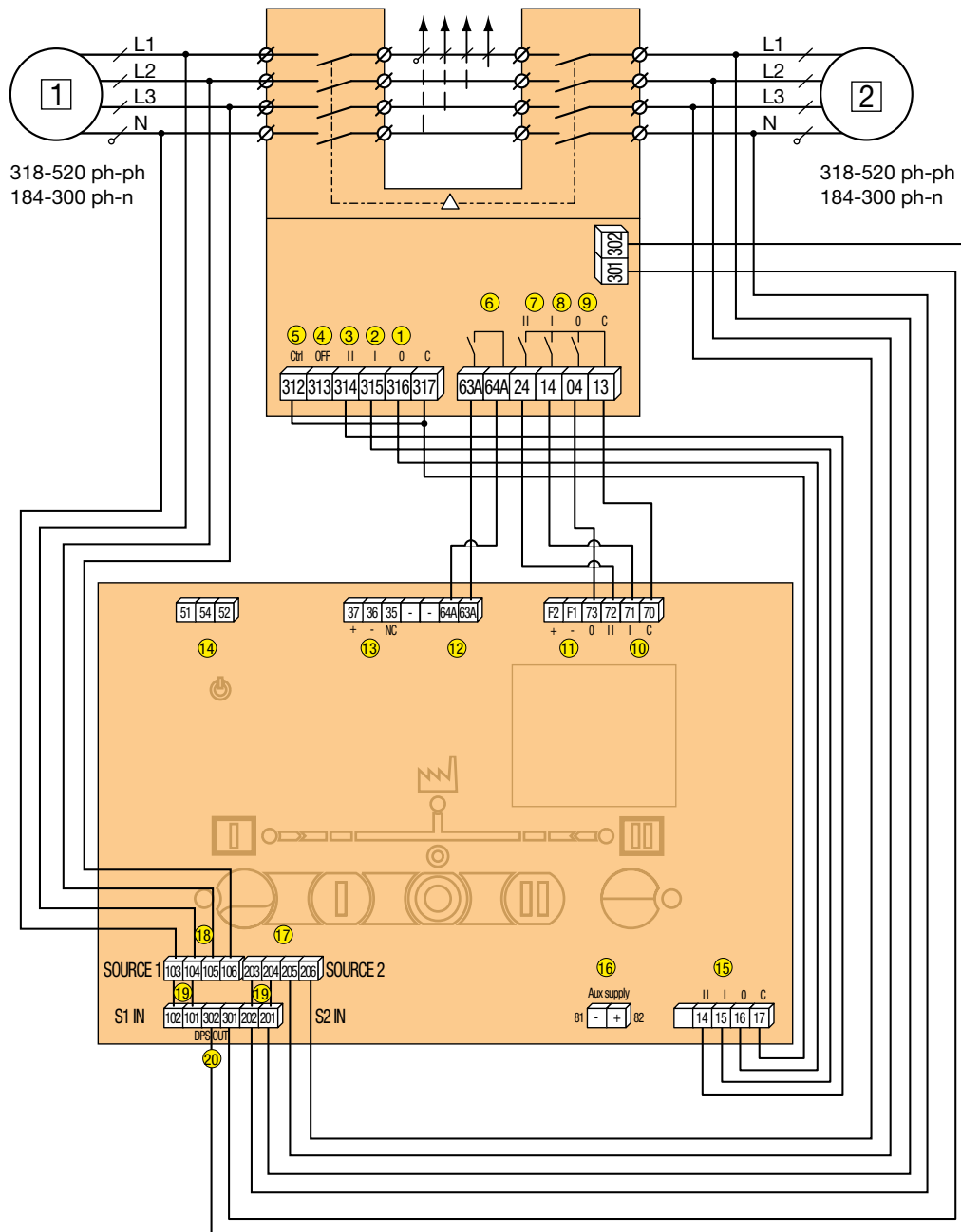

*Using a Socomec cable harness kit excludes the need for fuses

- 1 primary source (network or genset)
- 2 backup source (mains network or genset)

- 1: position 0 control (contact or logic if closed)
- 2: position I control
- 3: position II control
- 4: primary control position 0
- 5: closing this contact allows position control commands
- 6: product availability relay
- 7: auxiliary contact - closed when the switch is in position II
- 8: auxiliary contact - closed when the switch is in position I
- 9: auxiliary contact - closed when the switch is in position 0

- 10. Switch position inputs
- 11. 24 VDC fire input (forces 0 & inhibit)
- 12. Control inputs
- 13. ATyS C specific function : RS485 communication
- 14. Genset start NO/NC output
- 15. Control outputs to transfer device
- 16. 24 VDC aux power supply (for optional use)
- 17. Voltage sensing S2
- 18. Voltage sensing S1
- 19. DPS input (source 1 and 2)
- 20. DPS output to motor

Dimensions

125 to 630 A / B3 to B5

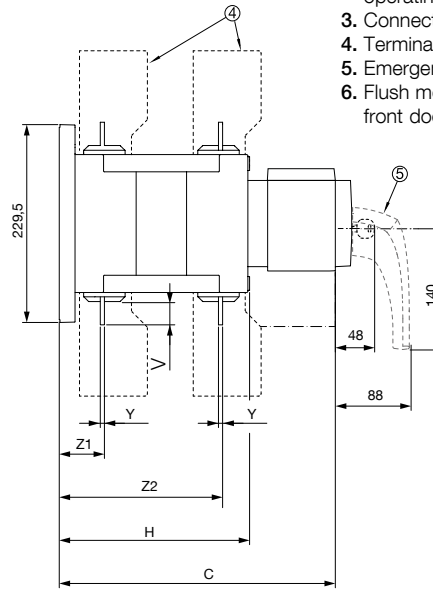
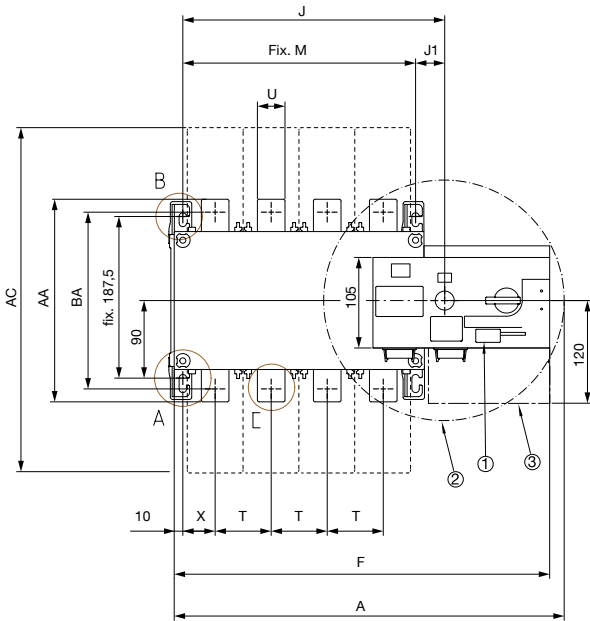

1. Padlocking Facility: Locking bracket for up to 3 padlocks of dia. 4 – 8mm
2. Emergency manual operation: Maximum operating radius with an operating angle of 2x 90°
3. Connection and disconnection area
4. Terminal shrouds
5. Emergency removable handle
6. Flush mounting cutout dimensions for front door

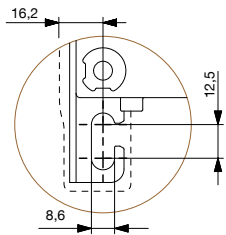

DETAIL A

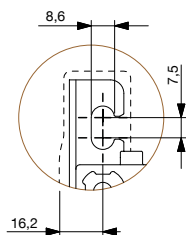

DETAIL B

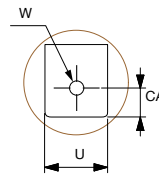

DETAIL C

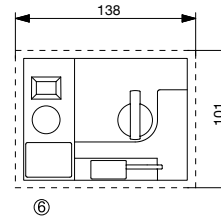

Ⓓ

atysc_042_a_x.ai

	125 A	160 A	200 A	250 A	315 A	400 A	500 A	630 A
	4 P	4 P	4 P	4 P	4 P	4 P	4 P	4 P
A	334	334	334	395	395	395	454	454
AA	135	135	135	160	170	170	260	260
AC	233	233	233	288	288	288	402	402
BA	115	115	115	130	140	140	220	220
C	244	244	244	244	244	244	321	321
CA	10	10	10	15	15	15	15	20
F	317	317	317	378	378	378	437	437
H	151	151	151	152	152	152	221	221
J	184	184	184	245	245	245	304	304
J1	34	34	34	35	35	35	34	34
M	150	150	150	150	210	210	270	270
T	36	36	36	50	50	50	65	65
U	20	20	20	25	35	35	32	45
V	25	25	25	30	35	35	50	500
W	9	9	9	11	11	11	14	13
X	22	22	22	33	33	33	37,5	37,5
Y	3.5	3.5	3.5	3.5	3.5	3.5	5	5
Z1	38	38	38	39.5	39.5	39.5	53	53
Z2	134	134	134	133.5	133.5	133.5	190	190

ATyS A - ATyS C

Automatic Transfer Switching Equipment
from 125 to 3200 A with split ATS controller

Dimensions (continued)

800 to 1600 A / B6 to B7

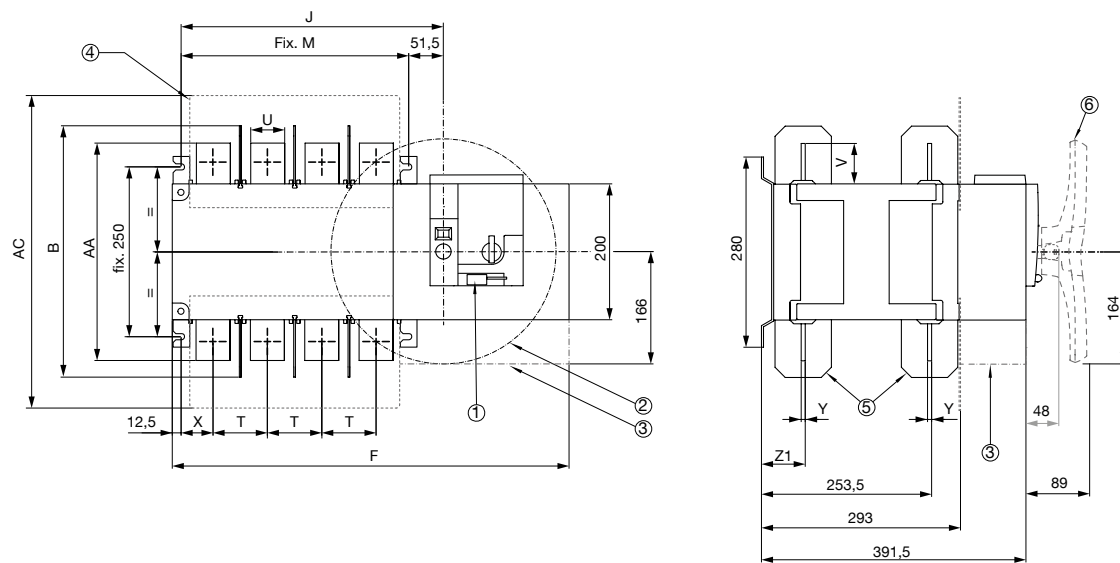

800 A - 1000 A

1250 A

1600 A

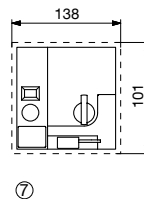
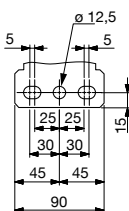
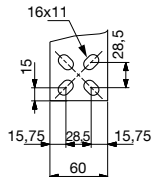
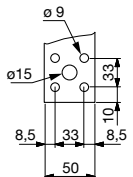
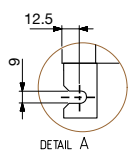

	800 A	1000 A	1250 A	1600 A
	4 P	4 P	4 P	4 P
AA	321	321	330	288
AC	461	461	461	531
B	370	370	370	380
F	584	584	584	716
J	387	387	387	519
M	335	335	335	467
T	80	80	80	120
U	50	50	60	90
V	60.5	60.5	65	44
X	47.5	47.5	47.5	53
Y	7	7	7	8
Z1	66.5	66.5	66.5	67.5

1. Padlocking Facility: Locking bracket for up to 3 padlocks of dia. 4 – 8mm
2. Emergency manual operation: Maximum operating radius with an operating angle of 2x 90°
3. Connection and disconnection area
4. Terminal screen
5. Phase Barriers
6. Emergency removable handle
7. Flush mounting cutout dimensions for front door

atysc_0413_a_x.ai

2000 to 3200 A / B8

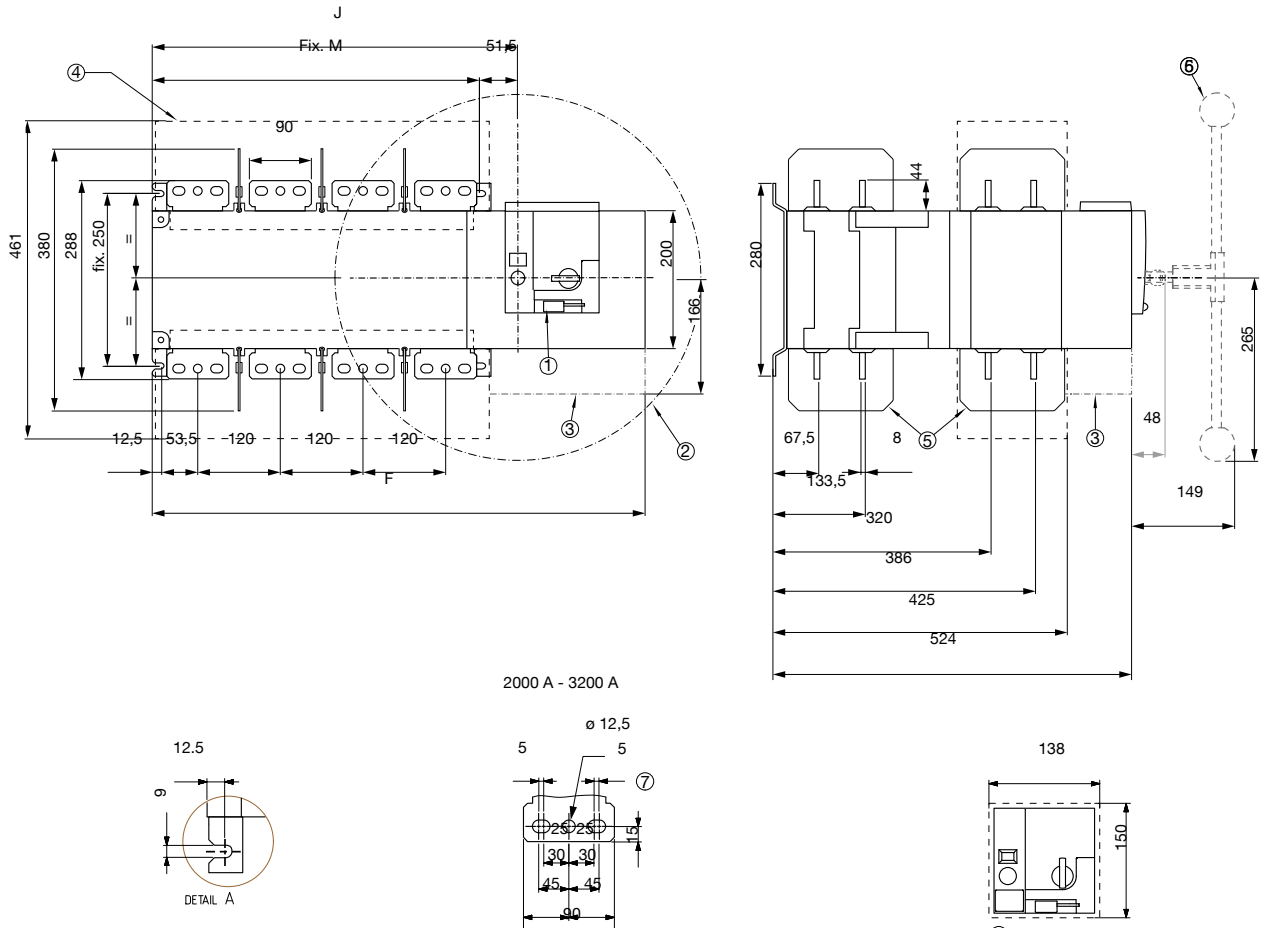

2000 A - 3200 A

	2000 A	3200 A
	4 P	4 P
F	716	716
J	518,5	518,5
M	467	467

1. Padlocking Facility: Locking bracket for up to 3 padlocks of dia. 4 – 8mm
2. Emergency manual operation: Maximum operating radius with an operating angle of 2x 90°
3. Connection and disconnection area
4. Terminal shields
5. Phase Barriers
6. Emergency removable handle
7. Frame B8, (Dual frame) factory fitted power terminal connections
1. Flush mounting cutout dimensions for front door